

PORTABLE WORKLIGHT

100-WL Series *Maximum 100 Watts Fluorescent*



Energy-saving illumination for task lighting. Vacuum-formed polycarbonate clear prismatic lens interior is engineered for maximum light control and diffusion; smooth exterior allows ease of cleaning; and rounded corners for additional impact strength and user safety. Housing is rigid one-piece construction, compression-molded fiberglass reinforced polyester. Continuous poured-in-place gasket completely fills the perimeter channel of the housing and snugly accepts lens flange for maximum seal integrity against moisture and dust. Oil/water-resistant 6' 18 AWG SJTOW black cord, three-prong NEMA 5-15 plug, and strain-relief cord fitting. Two 3 1/4" magnets (rated pull strength of 90 lbs. each) for beam support and 3/4" eyebolt, integral to the fixture, for overhead support by safety chain (not included). Water-resistant switch, zinc-plated steel handle with



Worklight on Optional Cart



Specifications

- Lens:** Vacuum-formed polycarbonate. Prismatic lens interior engineered for maximum light control and diffusion; smooth exterior allows ease of cleaning; and rounded corners for additional strength and user safety. Edge is flanged to fit snugly into the gasketed retention channel for a continuous seal against moisture and dust.
- Housing:** Rigid one-piece construction, compression-molded fiberglass reinforced polyester (self-extinguishing ASTM D635-74). Design and construction allows no flex during handling, thus reducing the possibility for damage.
- Gasket:** Continuous poured-in-place completely fills the perimeter channel of the housing and snugly accepts lens flange for maximum seal integrity against moisture and dust. Gasket cannot separate, shift, or fall out.
- Lamps:** Available with two 40-PLL(EB).
- Ballast:** 40PLL start 50°F. Electronic (EB).
- Hardware and Mounting Systems:** Two 3 1/2" magnets (rated 90 lbs. each) for beam support and 3/4" eyebolt, integral to the fixture for overhead support by safety chain (not included). Water-resist switch, zinc-plated steel handle with black non-conductive rubber coating. Four stainless steel latches.

- Cord, Plug, and Fittings:** Six-foot black cord, 18 AWG SJTOW, 3-prong NEMA 5-15 plug. Liquid Tight Fitting exceeds NEMA 6 specifications. Operates on 120V AC.



**SBA QUALIFIED
SMALL BUSINESS MANUFACTURER**

TAA COMPLIANT
TRADE AGREEMENT ACT COMPLIANT

ETL-US and ETL-C Listed
 USDA Certified for Food Area Applications.
 NSF Certified for Non-Food Zone Applications.

The polycarbonate lens carries a flammability rating of 94HB or better. The self-extinguishing fiberglass housing has the superior SE-O rating.

Luminaire Type _____
 Catalog Number _____
 Job Name _____
 Approval _____

WF Harris Lighting, Inc.™

Innovative Lighting Designs Since 1970
 P.O. Box 5023, Monroe, NC 28111-5023, USA
 704.283.7477 (HEADQUARTERS) • 800.842.9345 (TOLL FREE)
 e-mail: customerservice@wfharris.com
 www.wfharrislighting.com

Form 1562-2BJ

"A Live Operator Company Standing Ready to Serve Your Lighting Needs"

PORTABLE WORKLIGHT

Ordering Information (Fill In Blocks For Complete Catalog Number)

Model

100-WL-2-40-PLL(EB)

Option

CT-WL-

Hanging Device

Worklight Cart with oil-resistant casters rated for 75 lbs each load. Constructed of 13 gauge steel and painted with red enamel. Equipped with 45° tilt prop for side light positioning. Hardware provided. Simple assembly required. Dimensions: 22"L x 12 $\frac{5}{8}$ "W x 3 $\frac{5}{8}$ "D. Shipping weight: 10 lbs.

Dimensions

External Side View (Model 100WL)

External End View

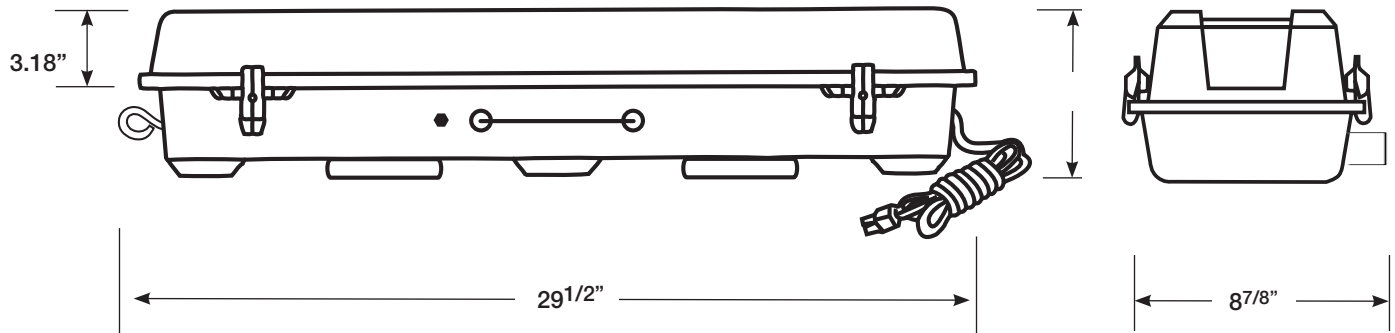

Weight

100-WL-2-40-PLL(EB) = 10.5 lbs.



**SBA QUALIFIED
SMALL BUSINESS MANUFACTURER**



Innovative Lighting Designs Since 1970

P.O. Box 5023, Monroe, NC 28111-5023, USA
704.283.7477 (HEADQUARTERS) • 800.842.9345 (TOLL FREE)
e-mail: customerservice@wfharris.com
www.wfharrislighting.com