

LED PORTABLE AREA WORKLIGHT

Model 300-WL-LED-1K-Daisy

Rust Resistant
Vandal Resistant
Nonconductive



Specifically designed to provide illumination in on-site production areas where endurance to environmental elements are as important as dependable, reliable service. **Whether operating in standard AC mode or battery backup operation, the Model 300 Worklight provides the same lumen output.** Two switches, one for AC power and another for DC power, allows the unit to be transported to another location without activating and draining the emergency battery pack. **Engineered with materials offering high resistance to rust, corrosion and impact.** Polycarbonate Safety Yellow housing is nonconductive, assuring more safety to the end user. Two maximum-secure magnets (pull strength rated 90 lbs. each) and one eyebolt, both integral to the worklight, allow convenient mounting either to a steel structure or overhead by a safety chain (not included). **Polycarbonate** lens with smooth exterior allows ease of cleaning and clear prismatic interior assures optimal lumen output. Ideally suited in the construction and assembly work in commercial, industrial, and government manufacturing operations.

LEDs contain no mercury and emit no ultraviolet light.

LEDs will not break, unlike conventional lamps, if luminaire is dropped.



Specifications

Lens:	Injection molded of UV-stabilized polycarbonate for lens impact strength and user safety. Average thickness is .125". Clear prismatic interior provides optimal lumen output and diffusion; smooth exterior surface allows ease of cleaning.
Base Plate:	Rust resistant .080" 5052 H-32 tempered marine-grade aluminum.
Housing:	Injection molded of UV-stabilized reinforced safety yellow polycarbonate for impact strength.
Gasket:	Lens gasket is closed-cell neoprene rubber for maximum dirt, dust and moisture barrier.
LEDs:	High Quality Lighting Grade LEDs 5,000K Color Temperature. Net Lumens = 1100 Warranted for five (5) years.
LED Life:	Lumen Maintenance (TM-21-11 70% Projection) 84,000 Hrs (25°C /77°F) = 10 years of 24/7 LED life 39,000 Hrs (50°C/122°F) = 4 years of 24/7 LED life Calculations Based on US Department of Energy Standards. DOE TM-21-11, 70%.
Driver:	High Quality Driver Class 2 Power Supply. AC Input: 120V, 50/60Hz Power = 10 W Efficacy = 110 Lm/W FC cRU us Complies with FCC rules and regulations, as per Title 47 CFR Part 15 Non-Consumer (Class A) for EMI/RFI (conducted and radiated) at full load. Warranted for five (5) years.

Cord, Plug and Fittings:	Six-foot black 18 AWG SJTOW cord, with 3-prong NEMA 5-15 plug. Liquid tight strain fitting exceeds NEMA 6 specifications.
Hardware:	Four stainless-steel 8-32x3/8 phillips truss head screws attach lens to base plate. On/Off Toggle Switch is hard plastic with rubber boot. Two maximum-secure Magnets pull strength rated for holding 90 lbs. each. One Eyebolt for mounting by safety chain (not included).
Backup Battery Pack	Nickel Cadmium (Ni-Cd) battery is maintenance free with a life expectancy of 5-7 years and provides over 90 minutes of battery backup operating time. During a power interruption when the unit is on, it automatically switches to battery operation. When AC power is restored, the battery is recharged within 48 hours, after which it will operation over 2 hours in DC mode with new batteries. Warranted for five (5) years by battery pack manufacturer. This product is not intended to take the place of a permanently-installed emergency fixture.

 **MADE IN AMERICA**

SBA QUALIFIED SMALL BUSINESS MANUFACTURER

TAA COMPLIANT
TRADE AGREEMENT ACT COMPLIANT

ETL-US and ETL-C Listed (UL 153)

All polycarbonate components meet Underwriters Laboratories 746C tests for polymeric material and carry a flammability rating of 94HB or better on lenses and the superior 94-5V rating on housings.

Luminaire Type _____

Catalog Number _____

Product Code _____

Job Name _____

Approval _____

WF Harris Lighting, Inc.™

Innovative Lighting Designs Since 1970

P.O. Box 5023, Monroe, NC 28111-5023, USA
704.283.7477 (HEADQUARTERS) • 800.842.9345 (TOLL FREE)
E-mail: customerservice@wfarris.com
www.wfharrislighting.com

Form 2570-2BJ

"A Live Operator Company Standing Ready to Serve Your Lighting Needs."

LED PORTABLE AREA WORKLIGHT

Ordering Information

Fill In Blocks For Complete Catalog Number

Model

300-WL-LED-1K-Daisy

Housing Color

HSY - Safety Yellow
(Other Housing Colors Available — Consult Factory for Pricing and Availability)

Hanging Device

HOOK - Open hook bolted to housing
Std. EYEBOLT - 3/4" center diameter (Please note: if box is blank, order will be delivered with the standard Eyebolt.)

Dimensions

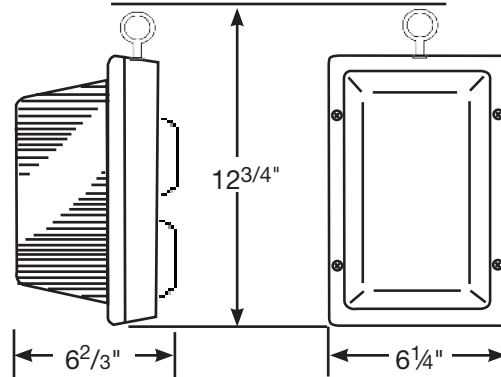

Weight

300-WL-LED-1K- Daisy = 4 lbs.

LEDs and the W. F. Harris Lighting Advantage

The lighting grade LEDs used by W. F. Harris Lighting provide the long sought-after stability demanded for commercial illumination in brightness, efficacy, life time, and color temperatures. Can be used in commercial and industrial illumination applications, hospitals, schools, universities, government buildings, military installations.

W. F. Harris Lighting LED-based luminaires reduce ownership costs through three factors —

- (1) Maintenance avoidance – LEDs last much longer than traditional lamps plus the worklight is rust resistant and vandal resistant;
- (2) Reduced energy cost of the LEDs;
- (3) LEDs will not break, unlike conventional lamps, if luminaire is dropped.

These lighting grade LEDs offer efficient illumination that - depending on the application - can last up to 84,000 hours before their light output falls below 70% of original illumination.



SBA QUALIFIED
SMALL BUSINESS MANUFACTURER

TAA COMPLIANT
TRADE AGREEMENT ACT COMPLIANT

LENS AND HOUSING CARRY A LIFETIME WARRANTY AGAINST BREAKAGE.

Specifications Subject to Change Without Notice.

W.F. Harris Lighting, Inc.™

Innovative Lighting Designs Since 1970

P.O. Box 5023, Monroe, NC 28111-5023, USA

704.283.7477 (HEADQUARTERS) • 800.842.9345 (TOLL FREE)

E-mail: customerservice@wfharris.com

www.wfharrislighting.com

© 2019 W. F. Harris Lighting, Inc.

Printed in USA

Form 2570-2BJ

“W. F. Harris Lighting Will Not Sacrifice Quality for the Sake of Price.”