

INDOOR BACK-LIT PANEL

BACK-LIT PANEL: E422

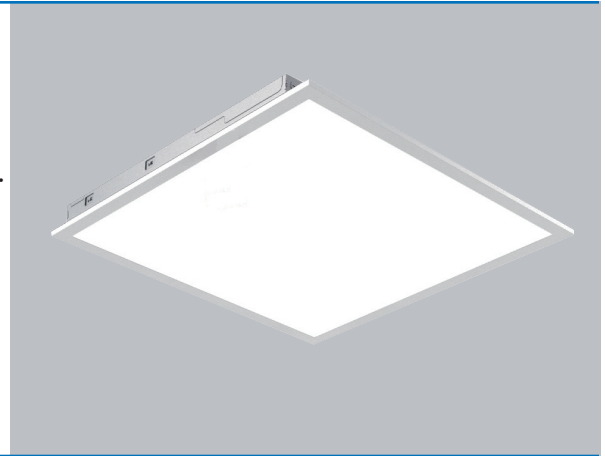

- Back-lit emitting, PMMA lens.
- Easy plug in sensor, NLC 5.0 Listed, PIR/Microwave/Bluetooth Sensor optional.
- Ultra slim design, only 34mm height, shipping cost effective.
- Integrated earthquake hook, recessed and suspension installation supportable.
- Factory or Field Install EB available, 90 mins backup time, Integrated test button, easy installation.
- Aluminum frame in white finish, Steel frame optional. steel die-formed back.



Dimensions

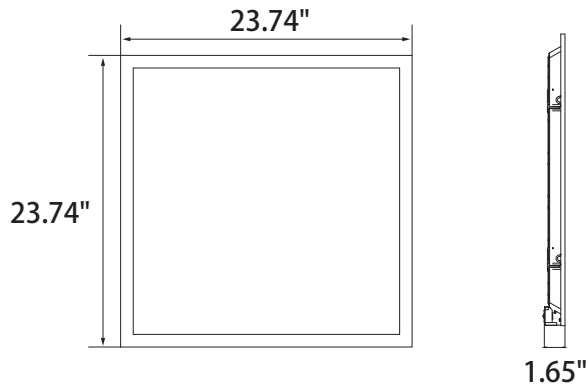

PHOTOMETRY

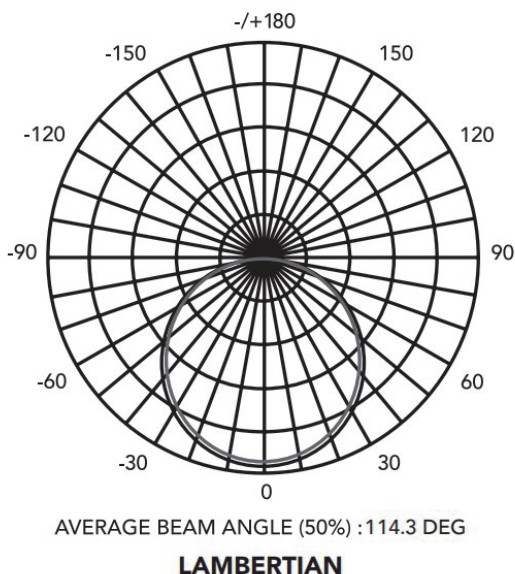

Specifications

Lumens (LM): 2250/3000/3750LM
Efficacy (LPW): 125LM/W
Input Voltage: 120-277V
CRI: > 80
Equivalency (W): 18/24/30W
Operating Temp: -20°C to 35°C
Warranty: 5 Years

WF Harris Lighting, Inc.

Innovative Lighting Designs Since 1970

4015 Airport Ext. Road • Monroe, NC 28110 USA
704.283.7477 (Headquarters) • 800.842.9345 (Toll Free)

E-Mail: customerservice@wfharris.com
www.wfharrislighting.com