

OUTDOOR ENTRY LIGHT

WALL LIGHT MODEL: E3060

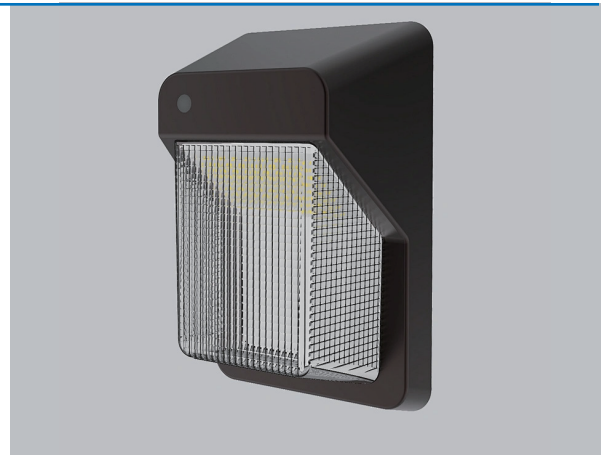

- Impact and weather resistant fixture with die cast back housing and polycarbonate Prismatic lenses. Prismatic lens for better glare control.
- Universal mounting plate with integral wire hooks for easy hands free installation.
- Bronze housing finish as stock, special order colors available (white, silver, gray, and black). Call for more information.
- Photocell included with optional photocell cap.
- Name brand chip and DOB technology with a five (5) year warranty.



Dimensions

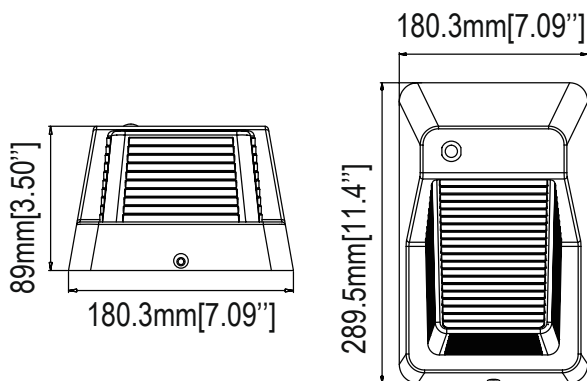

PHOTOMETRY

E3060

Mounting Height=10.00 FT

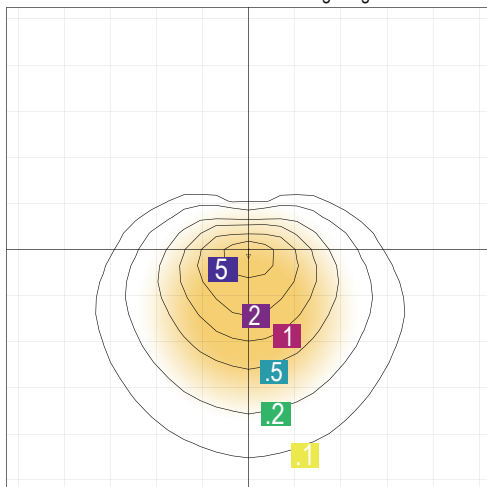

SCALE: 1 INCH = 15 FT.
LIGHT LOSS FACTOR = 1.00

MAXIMUM CALCULATED VALUE = 8.37 FC

FOOT CANDLE= .1 .2 .5 1 2 5

Specifications

Lumens (LM): 3375LM
Efficacy (LPW): UP TO 120LPW
Input Voltage: 120-277V
CRI: > 70
Equivalency (W): 100W MH
Operating Temp: -30 - 40°C
Warranty: 5 Years

WF Harris Lighting, Inc.

Innovative Lighting Designs Since 1970

4015 Airport Ext. Road • Monroe, NC 28110 USA
704.283.7477 (Headquarters) • 800.842.9345 (Toll Free)

E-Mail: customerservice@wfharris.com

www.wfharrislighting.com