

# LED LAMP FIXTURE

## 1000 Series *Rustproof Vandal-Resistant Wall Luminaire*



This wall bracket luminaire is as durable as it is attractive. Suitable for indoor/outdoor applications ranging from residential to commercial environments.

**Rust resistant.** Engineered with components and materials offering the **highest resistance to corrosion and impact.** The **polycarbonate** housing is nonconductive, assuring more safety to the end user. Ideally suited as security lighting for homes, schools, motels, hospitals, condominiums and industrial, commercial, and government buildings.

### Specifications

<b>Lens:</b>	Injection molded of UV-stabilized <b>polycarbonate</b> with threaded neck for twist-lock attachment. Average thickness is $\frac{1}{8}$ ". Smooth exterior surface for ease of cleaning.
<b>Bracket:</b>	Injection molded in black, white, or bronze UV-stabilized, reinforced <b>polycarbonate</b> . Equipped with threaded cup for lens attachment.
<b>Housing: (optional)</b>	Injection molded in black, white or bronze UV-stabilized, reinforced <b>polycarbonate</b> . Rear knockout for supply wire. Available with up to four threaded connections and plugs suitable for $\frac{1}{2}$ " conduit.
<b>Socket:</b>	Medium-base high temperature phenolic with copper screw shell, rated at 250V, 660W, with leads insulated for 200°C.
<b>Lamp:</b>	Uses a LED lamp. Provided by others.
<b>Hardware:</b>	Optional Lens-Lock screws are 1/4-20 socket set screws. Mounting hardware included.
<b>Mounting:</b>	Wall mounting only.



### Exploded View and Dimensions

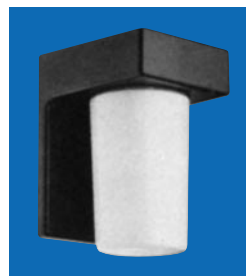
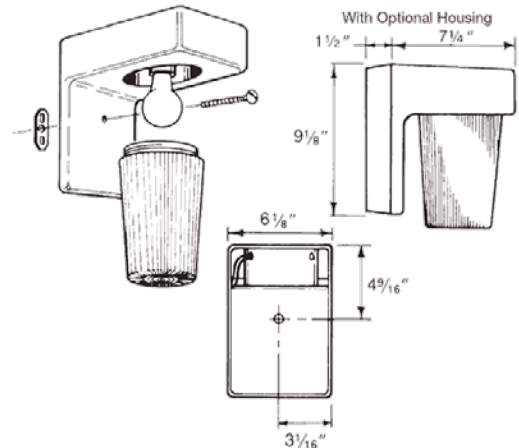

Shown With Opal White Lens



Shown With Optional Housing



**SBA QUALIFIED  
SMALL BUSINESS MANUFACTURER**  
**TAA COMPLIANT**  
TRADE AGREEMENT ACT COMPLIANT

### ETL-US Listed For Wet Locations.

All polycarbonate components meet Underwriters Laboratories 746C tests for polymeric material and carry a flammability rating of 94HB or better on lenses and the superior 94-5V rating on housings.

Luminaire Type \_\_\_\_\_  
 Catalog Number \_\_\_\_\_  
 Job Name \_\_\_\_\_  
 Approval \_\_\_\_\_

**Wf Harris Lighting, Inc.™**

**Innovative Lighting Designs Since 1970**  
 P.O. Box 5023, Monroe, NC 28111-5023, USA  
 704.283.7477 (HEADQUARTERS) • 800.842.9345 (TOLL FREE)  
 e-mail: customerservice@wfharris.com  
 www.wfharrislighting.com

Form 1526 -LED 2/25

*"A Live Operator Company Standing Ready to Serve Your Lighting Needs"*

# LED LAMP FIXTURE

Ordering Information (Fill In Blanks For Complete Catalog Number)

Model	Lens Color	Bracket and Housing Color	Lamp	Options	Conduit Connection
Model	Lens Color	Bracket and Housing Color	Lamp	Options	Conduit Connections
1000	<b>CP</b> -Clear Prismatic <b>OW</b> -Opal White <b>R</b> -Red <b>G</b> -Green <b>BY</b> -Buglight Yellow	<b>HK</b> -Black <b>HW</b> -White <b>HB</b> -Bronze	LED	<b>PC</b> -Photo Control <sup>2</sup> <b>LL</b> -Lens Lock <b>3H</b> _ - 1-1/2" Deep Housing (Specify Color) <b>K</b> -Black <b>W</b> -White <b>B</b> -Bronze <b>D3H</b> _ - 3" Deep Housing (Specify Color) <b>K</b> -Black <b>W</b> -White <b>B</b> -Bronze <b>GCO</b> -Grounded Convenience Outlet <sup>2,3</sup> <b>SW/B</b> -On/Off Switch with Boot <sup>2,4</sup>	<b>CRS</b> -Right Side <b>CLS</b> -Left Side <b>CT</b> -Top <b>CB</b> -Bottom <b>C4</b> -All Four Sides (Positions Based on Facing Luminaire)

<sup>1</sup> Provided By Others  
<sup>2</sup> Housing Required  
<sup>3</sup> Dry Locations Only  
<sup>4</sup> Interior Use Only



**SBA QUALIFIED  
 SMALL BUSINESS MANUFACTURER**



Specifications Subject to Change Without Notice

Luminaire is Warranted to be Free of Defects in Materials and Workmanship for One Year From Invoice Date.

**LENS AND HOUSING CARRY A LIFETIME WARRANTY.**

**W.F. Harris Lighting, Inc.™**

**Innovative Lighting Designs Since 1970**

P.O. Box 5023, Monroe, NC 28111-5023, USA  
 704.283.7477 (HEADQUARTERS) • 800.842.9345 (TOLL FREE)  
 e-mail: customerservice@wfharris.com  
 www.wfharrislighting.com

Printed in USA

Form 1526-LED

2/25

*"W. F. Harris Lighting Will Not Sacrifice Quality for the Sake of Price."*