

# OUTDOOR ENTRY LIGHT

## WALL LIGHT MODEL: E3050



- Impact and weather resistant fixture with full polycarbonate housings and lenses. Glare free and frosted lens for an inviting and even light distribution.
- Universal mounting plate with integral wire hooks for easy hands free installation. Pivot arm for ceiling mount and wall mount.
- Bronze housing finish as stock, special order colors available (white, silver, gray, and black). Call for more information.
- Photocell included with optional photocell cap.
- Name brand chip and DOB technology with a five (5) year warranty.



### Dimensions

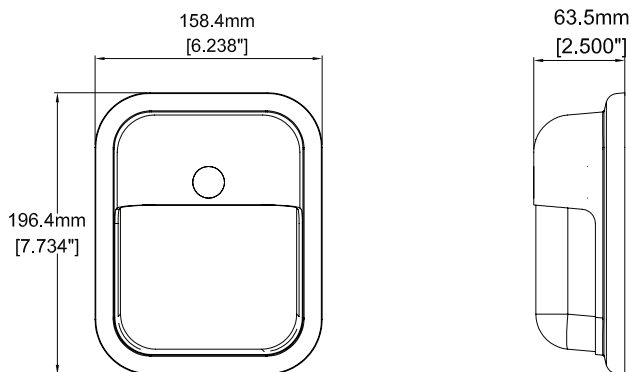

### PHOTOMETRY

**E3050**  
Mounting Height=12.00 FT

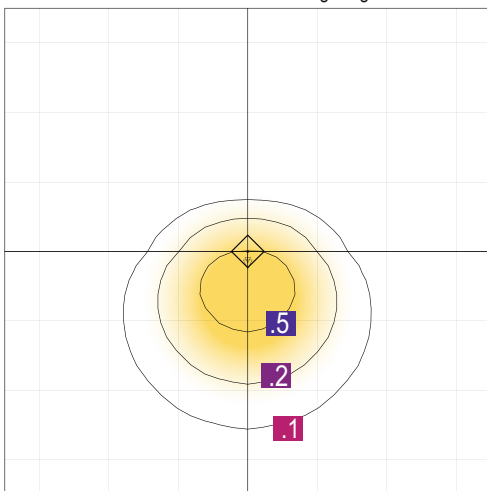

SCALE: 1 INCH = 12 FT.  
LIGHT LOSS FACTOR = 1.00

MAXIMUM CALCULATED VALUE = 0.88 FC  
FOOT CANDLE = .1 .2 .5

### Specifications

**Lumens (LM):** 945LM  
**Efficacy (LPW):** Up to 80LPW  
**Input Voltage:** 120V  
**CRI:** >80  
**Equivalency (W):** 35W MH  
**Operating Temp:** -30-40°C  
**Warranty:** 5 Years

# WF Harris Lighting, Inc.

**Innovative Lighting Designs Since 1970**

4015 Airport Ext. Road • Monroe, NC 28110 USA  
704.283.7477 (Headquarters) • 800.842.9345 (Toll Free)

E-Mail: [customerservice@wfharris.com](mailto:customerservice@wfharris.com)

[www.wfharrislighting.com](http://www.wfharrislighting.com)